

# SL-I 125

## INVERTED ROOF SEPARATION SHEET



0799



ArchiGreen Roof Ltd  
3 Patzay Pal Utca • Gyor • H-9024  
Website: [www.archigreenroof.com](http://www.archigreenroof.com)  
E-mail: [info@archigreenroof.com](mailto:info@archigreenroof.com)

SL-I 125 is a black needle punched non-woven geotextile that is thermally treated on both sides and weighs 125 g/m<sup>2</sup>. It is made of polypropylene fibres. Being polypropylene, the fibres used in the production of the FL and SL engineered fabrics:

- Demonstrate extreme durability
- Exhibit excellent resistance to naturally occurring acids and alkalis
- Possess low moisture absorption properties
- Exhibit excellent resistance to microorganisms and do not rot

Its low weight by unit area combined with its hydraulic properties and double-sided thermal treatment make this product the ideal choice for protection applications on inverted green roofs once rolled out on the specified thermal insulation as advised in the German FLL Guidelines.

### Use

Usage of the SL-I 125 layer include:

- Inhibition of the leeching of fine particles into the gaps between the insulation panels
- Facilitating the rapid dry out of the wet insulation layer
- Ensuring the continuous aeration of the build-up

### Application area

SL-I 125 protection layer is primarily used to protect the thermal insulation layer beneath a green roof from the leeching of fine growing medium particles or gravel into the gaps between the insulation panels. Being thermally treated on both sides, makes the SL-I 125 a hydrophobic layer. An overlapping of at least 150 mm is required between the adjacent separation sheets. Openings must be cut in the separation sheet above the roof outlets.

Size (L x W x H)	100 x 2 x Ø0.32 m
Weight	25 kg
Material	Polypropylene (PP)
Colour	Black
Effective pore size	0.09 mm
CBR puncture	1.7 kN
Cone drop test	28 mm
Tensile strength	
Warp (MD)	10 kN/m
Weft (CMD)	10 kN/m
Elongation at break	
Warp (MD)	45%
Weft (CMD)	50%
Environmental aspect	Fully recyclable

### Installation example

Carefully selected vegetation  
TDS semi-intensive substrate  
FL 200 filter layer  
SedumDrain® 25 water reservoir & drainage layer (infilled)  
SL-I 125 inverted roof separation layer  
XPS thermal insulation

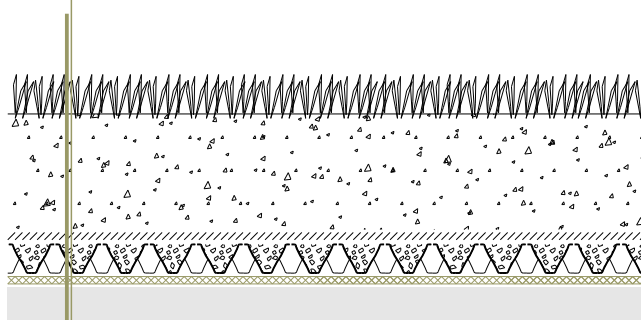

### Specification suggestion

ArchiGreen® SL-I 125 is a black separation sheet thermally treated on both sides made of rot-proof polypropylene. It is primarily used to protect the thermal insulation layer beneath a green roof from the leeching of fine growing medium particles, gravel or crushed brick into the gaps between the insulation panels. Being thermally treated on both sides ensures that the water absorption feature of the sheet is kept to a minimum. This product is CE-marked. Size: 100 x 2 x Ø0.32 m (L x W x H) [EN ISO 9863]. Weight: 25 kg [EN ISO 9864]. Effective pore size: 0.09 mm [EN ISO 12956]. Static puncture i.e. CBR test: 1.7 kN [EN ISO 12236]. Dynamic perforation test i.e. cone drop test: 28 mm [EN ISO 13433]. Tensile strength warp (MD): 10 kN/m; weft (CMD): 10 kN/m [EN ISO 10319]. Elongation at break warp (MD): 45 %; weft (CMD): 50 % [EN ISO 10319]. Water permeability normal to the plane - velocity index  $V_{H_{50}}$ : 100 mm/s [EN ISO 11058]. Microbiological resistance test: Minimum 25 years as per conditions set in the standard [EN 12225:2000]. Separation performance of the sheet exceeds the requirements set forth in the German FLL Guidelines. Delivery and installation is in accordance with manufacturer's instructions.



**Microbiological resistance EN 12225**  
25-year functionality warranted

### Technical illustration

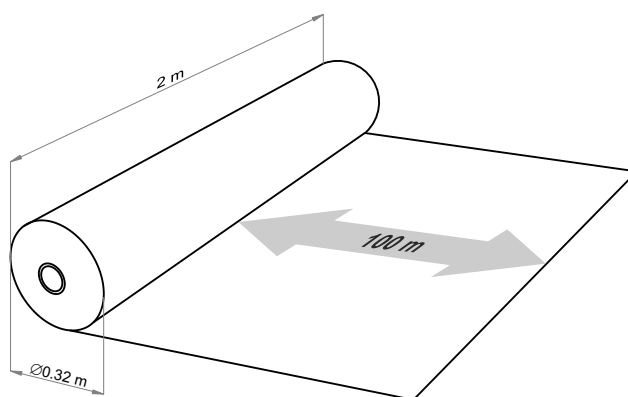

### Tools required

For safety purposes a hook cutter is advised when cutting the non-wovens. Never cut directly on the waterproofing or the root barrier.

### Packaging unit

SL-I 125 is despatched in rolls of 2 x Ø0.32 m each with the SL-I 125 filter sheet being rolled on carboard tubes and the whole roll is wrapped in a black polyethylene bag which is secured by a black cap on both ends of the tube. Weight: 25 kg/roll